

Millenia™



All Polymer Shelving



Will never rust or corrode in wet, outside, or humid environments

Shelf plates can be removed and are dishwasher-safe

Heavy-duty can support up to 1,000 lbs per shelf

Transforming The Way You Work and Store



Best

IN-STOCK



Ready to Ship!

Millenia™ Polymer Shelving

Millenia™ Polymer Shelving guarantees a premium storage option. This innovative new shelving system combines an easy to clean plus cost efficient technologies. System offers a multi-functional design and lifetime warranty against rust and corrosion. Unique dunnage add-on supports add stability and increase weight capacity on the lower shelf levels. Expert shelving consultants can help you prepare a complimentary 2D or 3D layout to help optimize your space.



EASY TO ASSEMBLE AND INSTALL

Shelves come preassembled for easier installation and can be adjusted on a 1" increment. No tools required.

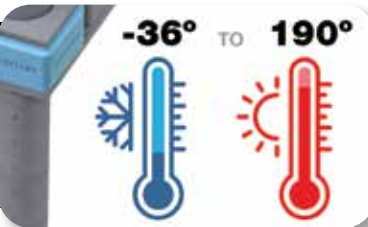

TEMPERATURE RANGE

With a wide temperature range, Millenia Shelving can be used in all extreme environments:

- Dry Storage
- Wet Storage
- Coolers
- Freezers



EASY TO CLEAN

Shelf plates can be easily removed for cleaning by hand or industrial dishwasher.



RUST AND CORROSION FREE

All Millenia Shelving is supported by a lifetime warranty against rust and corrosion. Its polymer composition makes it resistant to abrasive chemicals and wet environments.

PERFORMANCE FEATURES:

- Lifetime limited warranty
- Smooth or vented, open grid surface allows for air circulation and minimal dust buildup
- Easily removable and dishwasher safe shelf plates
- Up to 1,000 lb. load capacity per shelf evenly distributed and up to 2,000 lb. overall shelving unit **Dunnage stand recommended for units with 54" and longer shelves*
- No tools required for assembly
- National Sanitation Foundation (NSF) Approved
- Anti-microbial
- 100% rust proof
- Mobile capability available
- Shipped KD Class

SHELVING UNIT MATERIALS:

Beams/Side Connectors/
Adjustable Foot/Shelf
Conus/Connector

**Pultruded with glass
fibers and thermoset
resin composite**

Shelf Plates

**Polypropylene
(available in vented
or solid)**

Bumper

Reinforced nylon

Post Cap

Polypropylene

APPLICATIONS

Food service, walk-in coolers, healthcare storage, supermarket. Suitable to be used in wet, humid, or dry environments and applications.



MILLENIA™ Polymer Shelving Best

POST CAP
QPPC

(Sold as 4-pack)



POST
QPP14



Shelf can be adjusted on a 1" increments. No tools required

FLOOR ADAPTER
QPPA



SPLIT SLEEVES
QPSS

Included with all shelves
(Sold as 4-pack)



ADJUSTABLE HEIGHT SIDE AND BACK LEDGE

QPL24

2-1/4" Height



CLEAR LABEL HOLDER WITH 3" INSERTS

QPLH29C QPLHI-3



PRIVATE LABEL CAPABILITY



WIDTHS (W): 18", 21", 24"
LENGTHS (L): 24", 30", 36", 42", 48", 54", 60", 72"
HEIGHTS (H): 14", 26", 38", 50", 62", 74", 86", 98"



SOLID SHELF
QP1836SS



VENTED SHELF
QP1836VS

Up to 1,000 lb.
LOAD CAPACITY PER SHELF



DIVIDERS

QPDIV24

7-7/8" Height



MOBILE KIT

QPPSC-5S

Includes four swivel casters, 2 with brake and 4 donut bumpers



GUSSETS

QPG

Included with all shelves for extra support

BUILT FOR EFFICIENT AND CONVENIENT DRYING

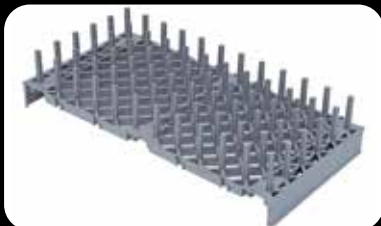

PRONGED DRYING CRADLE

QPDR1

Easily attaches to shelf frames.
Perfect for dishes, drying cups, glassware, or trays.
1-1/2" spacing between each 2-3/4"H prong.



PRONGED DRYING CRADLE

QPDR2

Easily attaches to shelf frames.
Perfect for dishes, drying cups, glassware, or trays.
2-1/2" spacing between each 2-3/4"H prong.



WAVED DRYING AND STORAGE CRADLE

QPWDR

Easily attaches to shelf frames.
Perfect for drying dishes, and flat boards.

Optimized Space Utilization

By using various accessories, multiple shelving configurations become possible without compromising the maximum load capacity of the shelving system.



ADD-ON UNIT CAPABILITY
(SIDE TO SIDE)



ADD-ON UNIT CAPABILITY
(L-SHAPE)



ADD-ON UNIT CAPABILITY
(U-SHAPE)

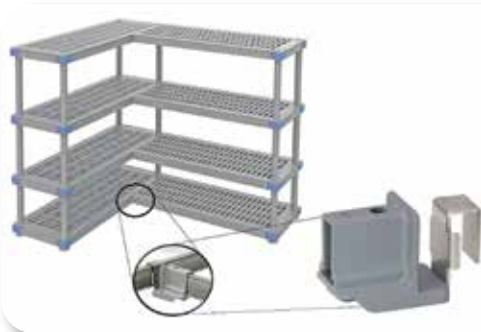

BEAM CONNECTOR ADAPTER
QP-HOOK

Used to connect multiple shelving units together
**Recommended for stationary units only*



CORNER COVER ADAPTER
QP-ADC

Weight Support

Keep your units safe and secure at all times.



DUNNAGE SUPPORT STAND*
QPDS

Allows for additional weight and stability
**Recommended for units with 54" high and longer shelves,*

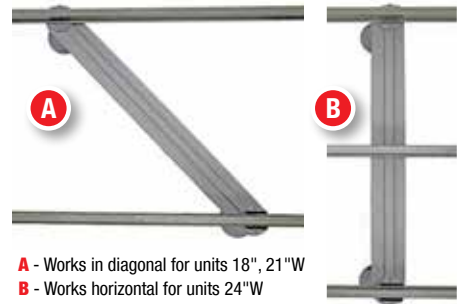

A - Works in diagonal for units 18", 21"W
B - Works horizontal for units 24"W



WALL BRACKET
QP-WMB

Used to secure a shelving unit from tipping over
**Recommended for stationary units only*

CONTACT US TODAY!

To view our full product line **VISIT US ONLINE.** quantumstorage.com

