

# NEW PRODUCT BULLETIN

# QUS270 BIN & CROSS DIVIDER

**NEW STYLE AVAILABLE NOW!**

**NEW 3 CROSS DIVIDER SLOTS**



**NEW CROSS DIVIDER**  
(Can divide bin in half or into thirds)

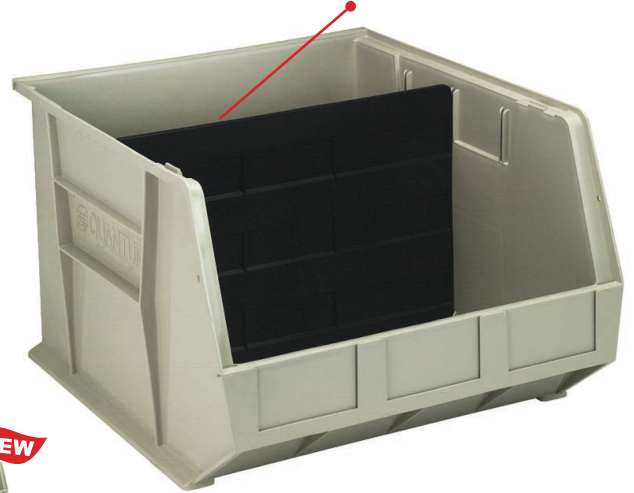

**QUS270**

Available in:



MODEL NO.	OUTSIDE DIMENSIONS L" x W" x H"	INSIDE DIMENSIONS L" x W" x H"	CTN X" QTY	CTN WGT	CLEAR WINDOW QTY	CTN DIVIDER QTY	CTN DIVIDER SLOTS	CROSS DIVIDER QTY	CTN DIVIDER SLOTS	CLEAR LABEL HOLDER & INSERT
<b>QUS270</b>	18" x 16-1/2" x 11"	17-1/8" x 14-3/4" x 10-1/4"	14" 3	25 lbs	<b>WUS270</b> 3	<b>DUS270</b> 6	3	<b>CRDUS270</b> 6	3	<b>LTR-2400</b>

## PERFORMANCE FEATURES AND BENEFITS

- 1 Full width hanger supports bin when hanging from louvered panels or rails
- 2 Reinforced rib design adds strength and prevents spreading
- 3 Extra-wide stacking ledge for secure stacking
- 4 Large front label slot allows larger bar code scanning and content identification
- 5 Anti-slide stop prevents stacked bins from shifting forward
- 6 Optional length or cross dividers increase storage options
- 7 Optional windows maximize storage capacity, prevent spillage and protect parts from dust and dirt



**CRDUS270**  
Cross Divider

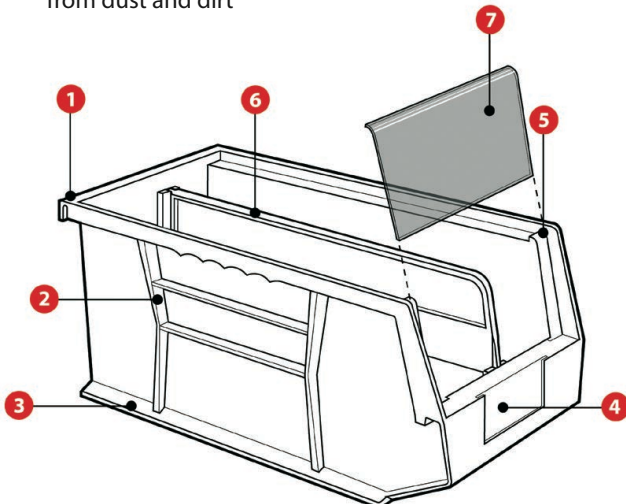

### CORPORATE HEADQUARTERS

15800 NW 15th Avenue  
Miami, Florida 33169  
Toll-Free 1-800-685-4665  
Fax 305-688-2790  
sales@quantumstorage.com  
[www.quantumstorage.com](http://www.quantumstorage.com)

