

HIGH DENSITY SLIDING TRACK SYSTEM

Top Track Available Fall 2011



Units slide back and forth with ease

Maximize Your Storage Space! High Density Sliding Track System

High Density Sliding Track System offers a unique way to maximize and efficiently move wire shelving systems. The patented design allows for quick and easy installation. Bearings in the skate are located under each post for a load capacity of 1,500 lbs. per shelving unit. The V-groove floor track allows the shelving unit to slide back and forth with ease. Layout assistance is available.

FEATURES AND BENEFITS:

- Cuts construction costs
- Low shipping cost
- NSF approved
- Uses industrial bearings
- Corrosion free construction
- Easy to roll construction
- Fast installation
- Utilizes the structure of existing shelving
- Complies with ADA regulations
- 1,500 lb. load capacity per unit
- Can increase storage areas up to 150%



LOWEST PRICE GUARANTEED!

STEP BY STEP ORDERING INSTRUCTIONS:
(Note: Shelves and posts to be purchased separately on pages 88-89)

Step 1 - Select desired length (in inches) of track. Use Model No.: QVTRK to order track. (Note that single units require two tracks and double units will require three tracks)

Step 2 - Select corresponding skate size from the chart, which will be the same as the depth of shelving unit to be utilized. Two skates required per single unit and three skates required per double unit. (Note, post height should not exceed a 4 to 1 ratio of skate size)

Step 3 - Purchase one End Stop Kit (Model No.: QESTP) per track length.

For each double unit being used, a Wing Kit (Model No.: WK) is required.

| MODEL NO. | DESCRIPTION | SHIP WGT |
|------------------------------|-------------------------|----------|
| Sliding Track Skates | | |
| HD18 | One 18" Skate | 4 lbs |
| HD21 | One 21" Skate | 5 lbs |
| HD24 | One 24" Skate | 6 lbs |
| HD30 | One 30" Skate | 7 lbs |
| HD36 | One 36" Skate | 8 lbs |
| Additional Components | | |
| QESTP | End Stop Kit | 1 lb |
| QVTRK | V-Track (Sold per inch) | 1 lb |
| WK | Wing Kit | 2 lbs |

Wing Kit
Model No.: WK

Includes four 1/4" thick plates & hardware and allows for the joining of 2 units side by side, sharing one track.

One Skate
Model No.: HD18 - HD36

V-Groove Track
Model No.: QVTRK
(Sold by the inch)

End Stop Kit
Model No.: QESTP

Includes 2 ends and 1 drill bit. Serves the dual purpose of stopping a skate and is the anchor for the track. One kit is required per track.

HIGH DENSITY SLIDING TRACK PACKAGES

SINGLE UNIT TRACK SYSTEM

(Top View)

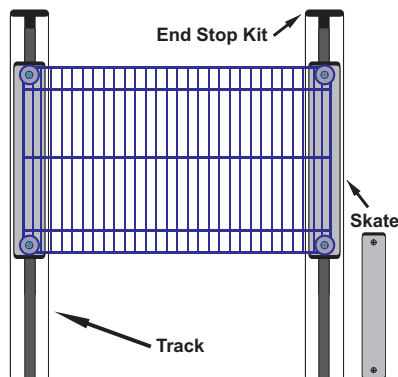

ORDERING INSTRUCTIONS:

- Step 1** - Select desired length of track and if you require:
- Single Unit track (use charts on left)
 - Double Unit track (use charts on right)
- Step 2** - Select corresponding skate size from single or double unit charts below. Skate size should match the depth of shelving unit being utilized.
- Step 3** - Using the chart on the bottom of this page, determine how many shelving units will fit on your track.
- Step 4** - Preconfigured 4-Shelf wire units are available on pages 90-93. Additional intermediate shelves are available on page 88.

DOUBLE UNIT TRACK SYSTEM

(Top View)

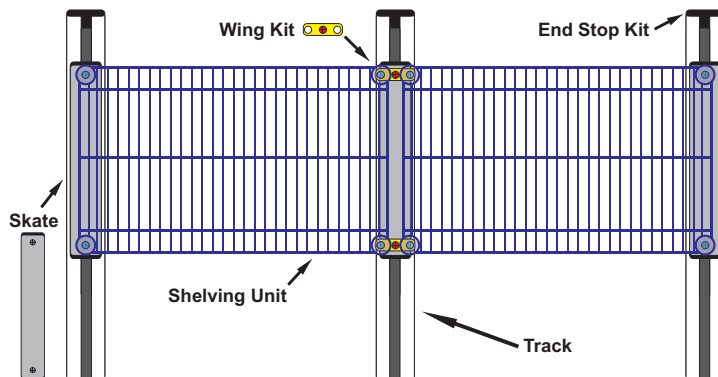

Single Unit Floor Track Assembly Kit

Assembly kit consists of a pair of aluminum tracks with end stop kits. Hardware and assembly instructions included. (Note: custom lengths may be purchased, see page 126)



Double Unit Floor Track Assembly Kit

Each assembly kit consists of three aluminum tracks with end stop kits. Hardware and assembly instructions included. (Note: custom lengths may be purchased, see page 126)

LOWEST PRICE GUARANTEED!

| MODEL NO. | TRACK L' (FT) | TRACK L" (IN) | SHIP WGT |
|---|---------------|---------------|----------|
| Single Unit Floor Track Assembly Kit Includes 2 Tracks of Specified Length with End Stop Kits | | | |
| QVTRK-2-72EST | 6' | 72" | 14 lbs |
| QVTRK-2-84EST | 7' | 84" | 16 lbs |
| QVTRK-2-96EST | 8' | 96" | 18 lbs |
| QVTRK-2-108EST | 9' | 108" | 20 lbs |
| QVTRK-2-120EST | 10' | 120" | 22 lbs |
| QVTRK-2-132EST | 11' | 132" | 24 lbs |
| QVTRK-2-144EST | 12' | 144" | 26 lbs |
| QVTRK-2-156EST | 13' | 156" | 28 lbs |
| QVTRK-2-168EST | 14' | 168" | 30 lbs |
| QVTRK-2-180EST | 15' | 180" | 32 lbs |
| QVTRK-2-192EST | 16' | 192" | 34 lbs |
| QVTRK-2-204EST | 17' | 204" | 36 lbs |
| QVTRK-2-216EST | 18' | 216" | 38 lbs |
| QVTRK-2-228EST | 19' | 228" | 40 lbs |
| QVTRK-2-240EST | 20' | 240" | 42 lbs |

| MODEL NO. | TRACK L' (FT) | TRACK L" (IN) | SHIP WGT |
|---|---------------|---------------|----------|
| Double Unit Floor Track Assembly Kit Includes 3 Tracks of Specified Length with End Stop Kits | | | |
| QVTRK-3-72EST | 6' | 72" | 21 lbs |
| QVTRK-3-84EST | 7' | 84" | 24 lbs |
| QVTRK-3-96EST | 8' | 96" | 27 lbs |
| QVTRK-3-108EST | 9' | 108" | 30 lbs |
| QVTRK-3-120EST | 10' | 120" | 33 lbs |
| QVTRK-3-132EST | 11' | 132" | 36 lbs |
| QVTRK-3-144EST | 12' | 144" | 39 lbs |
| QVTRK-3-156EST | 13' | 156" | 42 lbs |
| QVTRK-3-168EST | 14' | 168" | 45 lbs |
| QVTRK-3-180EST | 15' | 180" | 48 lbs |
| QVTRK-3-192EST | 16' | 192" | 51 lbs |
| QVTRK-3-204EST | 17' | 204" | 54 lbs |
| QVTRK-3-216EST | 18' | 216" | 57 lbs |
| QVTRK-3-228EST | 19' | 228" | 60 lbs |
| QVTRK-3-240EST | 20' | 240" | 63 lbs |

Single Unit Skate Assembly Kit

Each kit includes two skates and all appropriate hardware. One kit is required for each single mobile unit. (Shelves and posts sold separately on pages 88 and 89)

| MODEL NO. | DESCRIPTION | SHIP WGT |
|---------------------------------------|----------------|----------|
| Single Unit Skate Assembly Kit | | |
| HD18-2 | Two 18" Skates | 8 lbs |
| HD21-2 | Two 21" Skates | 10 lbs |
| HD24-2 | Two 24" Skates | 12 lbs |
| HD30-2 | Two 30" Skates | 14 lbs |
| HD36-2 | Two 36" Skates | 16 lbs |

Double Unit Skate Assembly Kit

Each kit includes three skates and all appropriate hardware. One kit is required for each double mobile unit. (Shelves and posts sold separately on pages 88 and 89)

| MODEL NO. | DESCRIPTION | SHIP WGT |
|---------------------------------------|-----------------------------|----------|
| Double Unit Skate Assembly Kit | | |
| HD18-3 | Three 18" Skates + Wing Kit | 15 lbs |
| HD21-3 | Three 21" Skates + Wing Kit | 18 lbs |
| HD24-3 | Three 24" Skates + Wing Kit | 21 lbs |
| HD30-3 | Three 30" Skates + Wing Kit | 24 lbs |
| HD36-3 | Three 36" Skates + Wing Kit | 27 lbs |

QUANTITY OF SHELVING UNITS BY WIDTH TO FIT ON LENGTH OF TRACK*

| | 6' | 7' | 8' | 9' | 10' | 11' | 12' | 13' | 14' | 15' | 16' | 17' | 18' | 19' | 20' |
|-----|----|----|----|----|-----|-----|-----|-----|-----|-----|-----|-----|-----|-----|-----|
| 18" | 2 | 2 | 3 | 4 | 4 | 5 | 6 | 6 | 7 | 8 | 8 | 9 | 10 | 10 | 11 |
| 21" | 1 | 2 | 2 | 3 | 4 | 4 | 5 | 5 | 6 | 6 | 7 | 8 | 8 | 9 | 9 |
| 24" | 1 | 2 | 2 | 3 | 3 | 4 | 4 | 5 | 5 | 6 | 6 | 7 | 7 | 8 | 8 |
| 30" | 1 | 1 | 2 | 2 | 2 | 3 | 3 | 4 | 4 | 4 | 5 | 5 | 6 | 6 | 6 |
| 36" | 1 | 1 | 1 | 2 | 2 | 2 | 3 | 3 | 3 | 4 | 4 | 4 | 5 | 5 | 5 |

* Using a minimum 36" aisle space. Note, post height should not exceed the skate length by a 4 to 1 ration (example 18" skate should not exceed a 74" post)